

STATUS OF THE STORAGE RING

As a storage ring to be installed at Ritsumeikan University, the superconducting compact storage ring AURORA designed and manufactured by Sumitomo Heavy Industries was chosen, on which description was given elsewhere [1–3]. After some modification of the original design, the ring was installed in April 1996 in the Biwako-Kusatsu campus and has successfully been operated since then [4, 5].

Injector is a race-track-type microtron which provides an electron beam of 1mA at an energy of 150MeV to the storage ring at a repetition rate of 10Hz. A 1/2 integer resonance injection method is adopted [6]. The ring is composed of a superconducting weak-focusing single-body magnet, in which the electron orbit is exactly circular with the radius of 0.5m. Figure 1 shows the horizontal and vertical cross section of the ring. The energy of accumulated electron beam is boosted up to 575MeV synchronously with an increase in the field strength of the magnet. The ring is normally operated at energy of 575MeV with an initial beam current of 300mA. It takes about 30s to inject an electron beam into the ring and about 8 min to accelerate the electron beam up to 575MeV. The critical energy of the radiation is 844eV, higher than that of other rings of approximately the same beam energy. This is due to the smaller radius of the electron orbit in the strong magnetic field, 3.8T. Table 1 lists the parameters of the ring [7–9].

The total operation time of the ring in the fiscal year of 2007 is 1600 hours, of which 94% is user time, 1% time for machine study and 5% time for tune-up of the ring. Integrated beam current (dose, i.e., accumulated beam current multiplied by operation hours) reaches 310 A·h (ampere-hours). Total user time in the fiscal year was 1500 hr. Some troubles occurred at the injection system and helium refrigerator system.

Injection of an electron beam into the ring was made twice a day. Initial beam current was about 300mA and it decreased to about 150mA at the end of each operation. Figure 2 shows the typical variation in the stored beam current in a day.

References

- [1] N. Takahashi, *Nucl. Instrum. Methods*, **B24/25** (1987) 425.
- [2] H. Yamada and SHI Accelerator Research Group, *Rev. Sci. Instrum.*, **60** (1989) 1786.
- [3] H. Yamada, *Proc. Asian Forum on Synchrotron Radiation*, ed. T. Ohta, S. Suga and S. Kikuta, Ionics Pub., Tokyo, (1994) p.227.
- [4] H. Iwasaki, *Proc. 3rd Asian Forum on Synchrotron Radiation*, (1997) p.113.
- [5] H. Iwasaki, Y. Nakayama, K. Ozutsumi, Y. Yamamoto, Y. Tokunaga, H. Saisho, T. Matsubara and S. Ikeda, *J. Synchrotron Radiation*, **5** (1998) 1162.

- [6] T. Takayama, *Nucl. Instrum. Methods*, **B24/25** (1987) 420.
- [7] Y. Yamamoto, I. Sakai, T. Mitsuhashi, D. Amano and H. Iwasaki, *Nucl. Instrum. Methods*, **A 467-468** (2001) 921-924.
- [8] I. Sakai, Y. Yamamoto, T. Mitsuhashi, D. Amano and H. Iwasaki, *Nucl. Instrum. Methods*, **A 480** (2002) 373-378.
- [9] Y. Yamamoto, T. Hori, I. Sakai, K. Yadomi and H. Iwasaki, *Nucl. Instrum. Methods*, **A 533** (2004) 505-508.

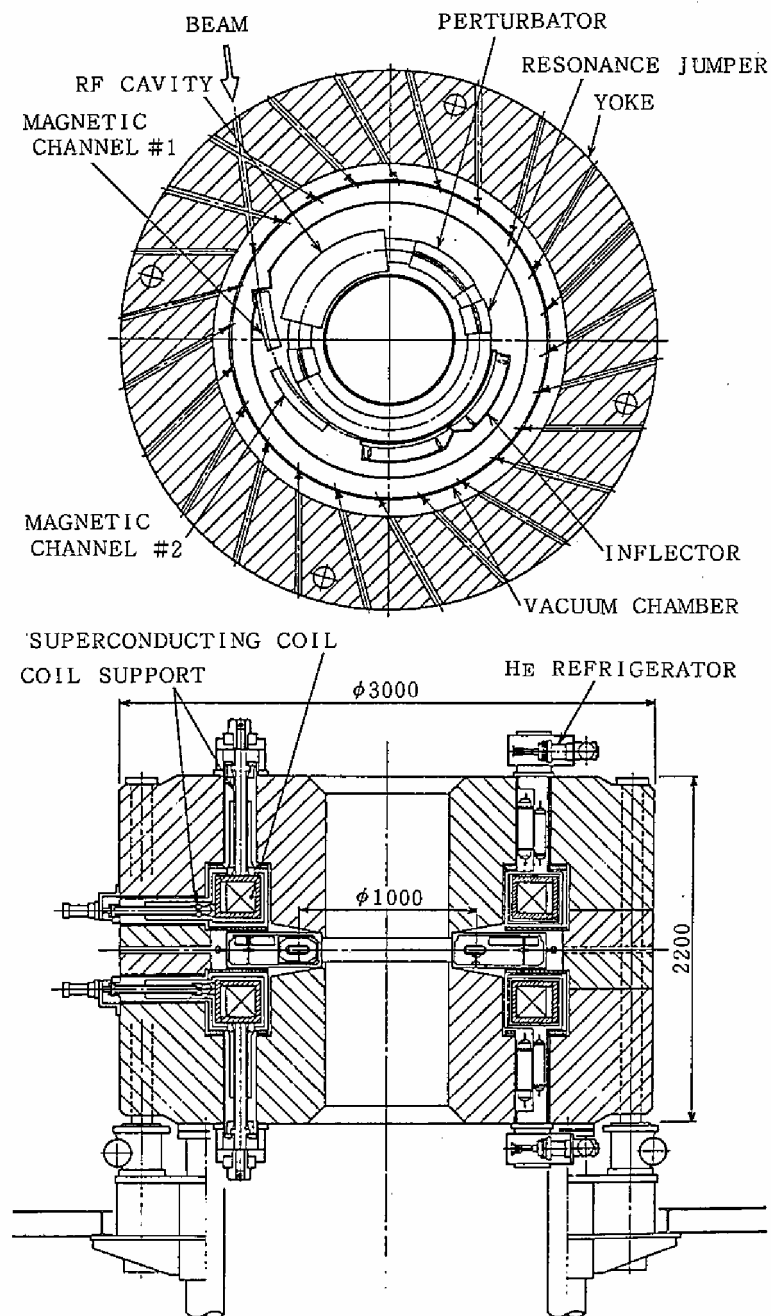

Fig.1. Horizontal and vertical cross section of the storage ring.

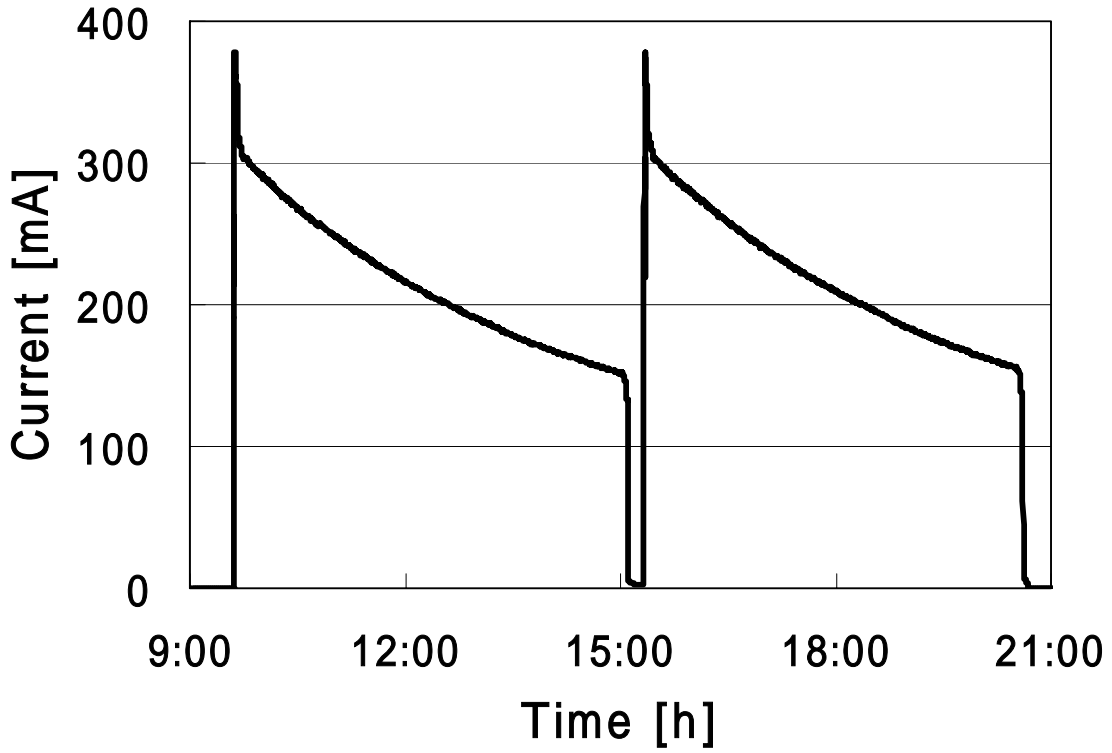

Fig.2. Typical variation in the accumulated electron beam current in a day.

Table 1. Parameters of the injector and storage ring

Injector		
Energy	150	MeV
Repetition	10	Hz
Peak current	1	mA
Pulse width	2	μ s
Storage Ring		
Energy	575	MeV
Stored current (e^-)	300	mA
Circumference	3.14	m
Radius of curvature	0.5	m
Field strength	3.8	T
RF frequency	190.86	MHz
Number of cavity	1	
Harmonic number	2	
Critical energy of radiation	844	eV
Beam size	1.2	mm(horizontal)
	0.13	mm(vertical)